

Model 524-RF/SR paired with the Rip Navigator Scout-HS: THE ULTIMATE IN OPTIMIZING

Operator intervention station with servo controlled lasers integrated to Rip Navigator controls allow operators to see the computer generated solution and if required, edit.

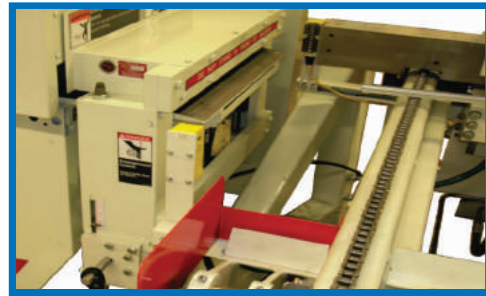

Mereen-Johnson Power Tables feature dual rolls with pressure compensated drive and timing features for accurate feeding and minimal saw feed bed wear.



Robust steel tube and plate construction maximizes performance, increases longevity and reduces maintenance requirements

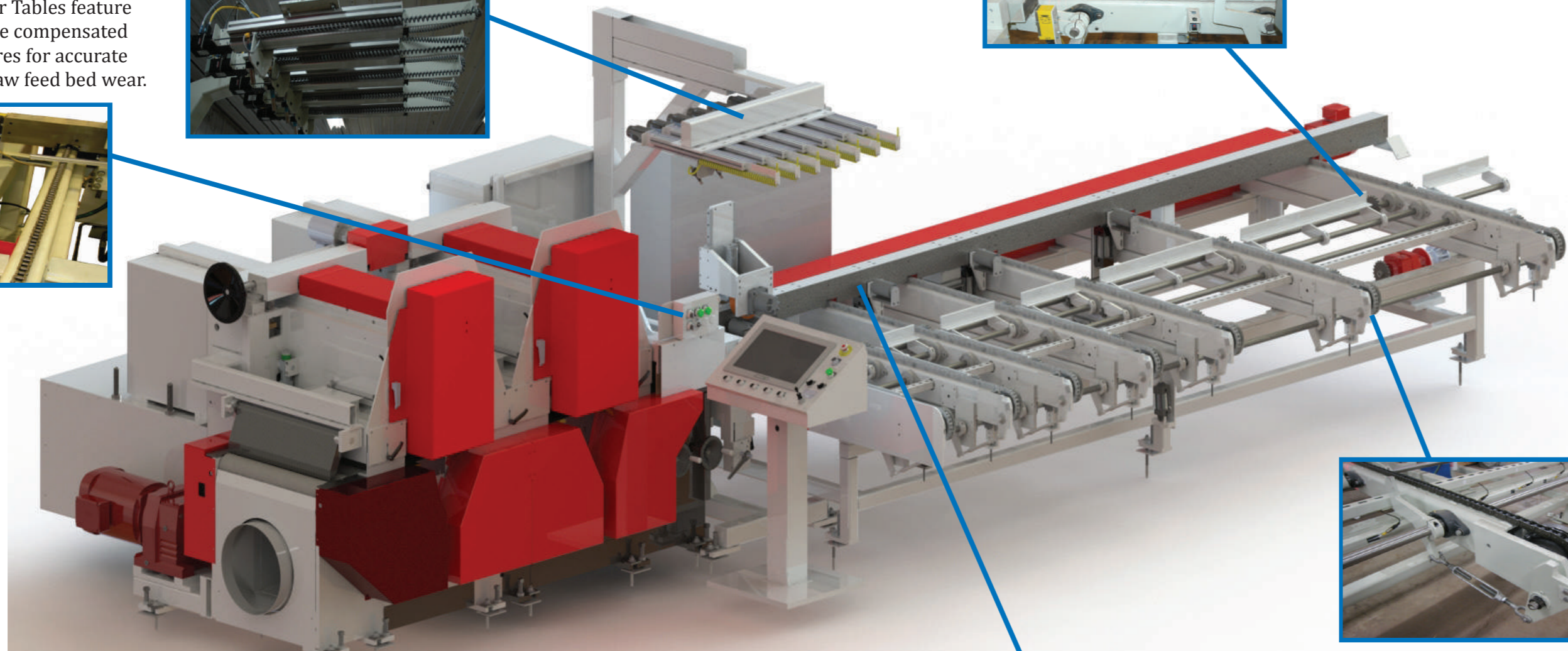

Accumulator arms with integrated board dealer allows a single operator to control the system

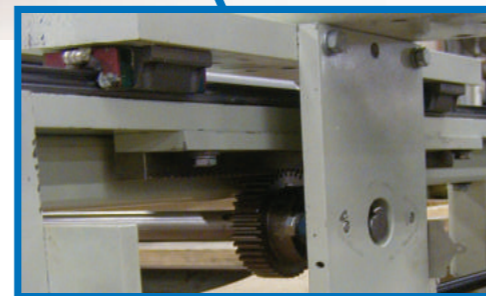

System guide is mounted on linear ways for smooth and accurate positioning integrated with Rip Navigator control. Integral upper and lower rolls both jump for accuracy and reduced wear.

Rip Navigator Scout-HS for the Roll Feed

- Up to 20 boards, 16 feet in length per minute
- Scans lumber for width, length & crook
- Ships fully assembled for fast and easy set-up
- Random width part capability on Select Rip Saws
- Integrates perfectly with Mereen-Johnson Roll Feed Ripsaw
- Real time recording can turn off rips when production requirements are met
- Programmable cut bill will only rip strips which meet your length & cross cut requirements

Optional 2-sided Hogging Virtually Eliminates Edgings

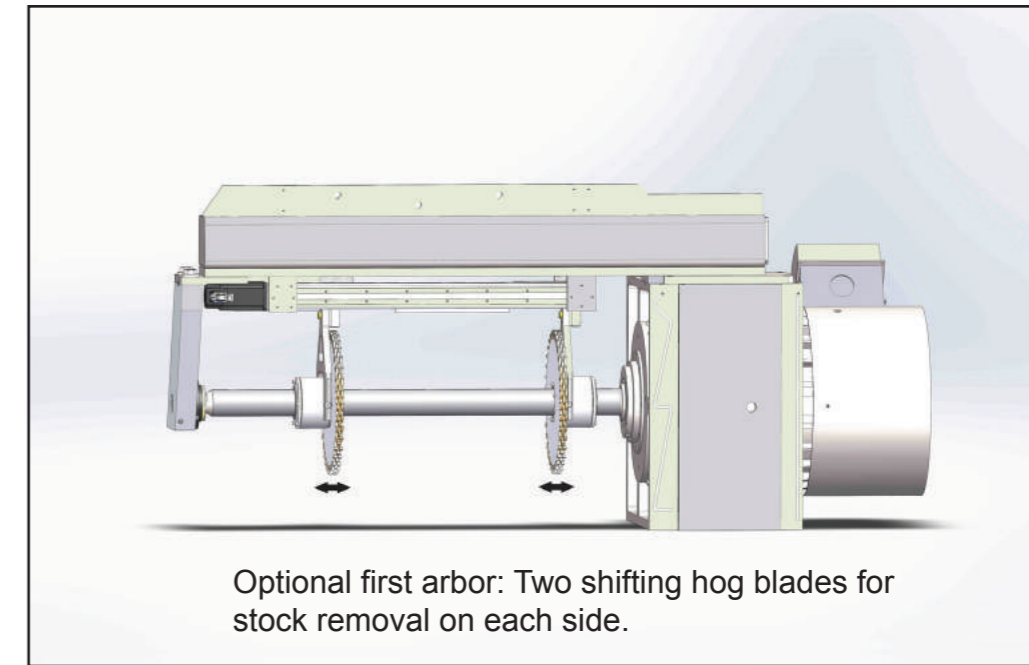

Optional first arbor: Two shifting hog blades for stock removal on each side.

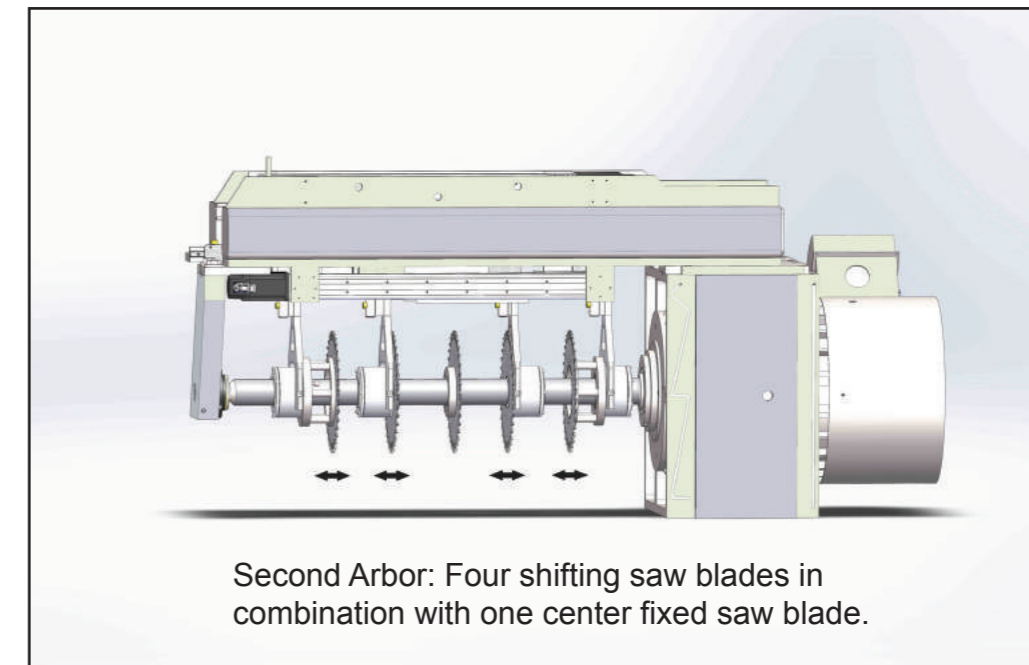

Second Arbor: Four shifting saw blades in combination with one center fixed saw blade.



Value

- Extremely robust construction providing greatest durability & longevity.
- Designed for low maintenance providing the lowest total cost of ownership.
- The industry's best re-sale value.
- The best warranty and after sales service.

LEADING TECHNOLOGY -- LASTING PERFORMANCE